

# WINTON WOOD CHIPPER

## WWC SERIES



**OWNERS MANUAL**

**PLEASE READ THIS MANUAL BEFORE OPERATING THE CHIPPER**

Congratulations on purchasing your new **Winton** wood chipper

Before you get started, we have provided a helpful space to jot down a few important details about your new Winton machine.

Model Number: **WWC**

Serial Number:

Date of purchase:

Factory Reference: **WCX5**

This manual should be considered a permanent part of this machine and should remain with it even if the machine is subsequently sold.

Winton continually seeks advancements in its product design and quality. Therefore, while this manual contains the most current product information available at the time of printing, there may be minor discrepancies between your machine and this manual.

If you have any questions concerning this manual, please consult your local dealer.

## **General Safety Information**

Ensure all potential operators read this manual thoroughly before using the machine.

**Safety:** Ensure tractor and machine is stopped & keys out of ignition before set-up/maintenance.

**Safety:** Failure to follow good safety standards could result in severe injury or even death.

**Misuse:** This machine is designed for use with compact tractors, and should be used only for the indicated purpose. Winton does not take responsibility if the machine is used for any other purpose. Children must not operate the machine under any circumstance.

**Modification:** Do not modify equipment in any way. This may impair the operation and overall safety of the machine.

**Tractor requirements:** Use only with compact tractors within power range specified.

**Misuse transport:** Do not use machinery to transport personnel or livestock.

**Condition:** For the safety of personnel and optimum performance of the machine, you should check the condition of the machine and the tractor before starting. Before use check all nuts and bolts are tight.

**Spatial awareness:** Always check the operating area is safe before starting machinery.

**Operator clothing:** The operator should not wear loose clothing while operating machinery.

**Safety wear:** Always use appropriate ear protection when running a tractor and machinery. Ensure you are wearing protective gloves when servicing and using machinery.

**Bystander safety:** Ensure bystanders keep away from the machine when it is in use. Do not touch moving parts when the machine is at work.

**Public places:** When travelling on the road/public places, always keep the PTO turned off.

**Maintenance:** Always keep the machine maintained and in a good state. Where necessary, repair or replace any defective parts. Do not modify the machine.

**Sharp objects:** Pay attention to the sharp/pointed parts while servicing the machine.

**Safety guards:** All protective parts should be in good condition before operating machinery.

**Safety signs/stickers:** Keep all safety signs clean and legible. Replace any which are missing or illegible. If a component with safety sign/(s) is replaced, make sure new safety sign/(s) are attached in the same locations.

**Operating speeds:** Machinery and PTO should be operated at the recommended speed at all times.

**Safety awareness:** Good safety requires that you familiarise yourself with various safety signs, the type of warning and the area, or particular function related to that area.

**Alertness:** Never consume alcohol or drugs these can hinder alertness/coordination. Consult your doctor about using this machine while taking prescription medications.

## **General Safety Information (continued)**

### **Machinery Pre-Use Checks**

On receipt of your new Winton machine and again within the first 4 hours of use, or the 'shake in' period as we like to call it, we always recommend checking over the machine.

- Check all bolts, nuts and screws are tight on the unit.
- Tighten/check any bolts and nuts securing blades.
- If your machine has belts check the tension and adjust if required.
- Apply grease to grease points if necessary.
- Check gear oil level and top up if needed. Do not overfill.

### **Tractor Pre-Use Checks**

Check that the machine is properly attached to the tractor. Ensure that secure pins are used on the linkage mounting pins.

Be sure to add extra weights to the front of the tractor or add wheel weights if required.

Check that the tractor PTO shaft turns freely and that the machines PTO drive shaft can extend easily. Grease the PTO drive shaft using the grease points.

The chain on the PTO shaft should be checked and in a good condition. The universal joints installed should be in a good state, with proper protective parts.

Before installing the PTO shaft, the tractor and machine should be stopped and remove the key.

Install and secure all safety guards, doors and covers before starting.

Bystanders should leave the immediate area before connecting the drive from the tractor.

### **Running/Operating Checks**

- Always keep the PTO output from the tractor at **540 RPM** when running machinery.

### **Post-Use Regular Checks**

Check blades, belts and wearing parts. Be sure they are not damaged and blades swing freely in their mount. Repair or replace as required.

Clean machinery and check for/clear any entangled material which may have got stuck around any rotating parts.

# Contents

	Pg.
General Safety information	1-2
1. Dimensions and Specifications	3
2. Installation & Set Up	4
3. Flywheel Blade Replacement	5
4. Bed Blade Adjustment & Replacement	6
5. Operating Procedure & Advice	7
6. Servicing & Maintenance	8
7. Safety Signs	9
8. Parts Diagram 1	10
9. Parts List 1	11
10. Parts Diagram 2	12
11. Parts List 2	13
12. Parts Diagram 3	14
13. Parts List 3	14
PTO Shaft Resizing	
Winton Product Warranty	
Trouble Shooting	

## 1. Dimensions & Specifications

Model	WWC
Weight	195kg
Max. Wood Diameter	13cm / 5inch
PTO Turning Speed	540 RPM
No. Of Blades & Blade Type	1x bed (reversible) 4 x flywheel (reversible)
Recommended Tractor HP	14-48 hp
Width	140cm
Depth	130cm
Height	160cm
PTO Shaft Size	70cm
Linkage Size	Category 1

## **2. INSTALLATION & SET UP**

**Safety:** Ensure tractor and machine is stopped & keys out of ignition before set-up/maintenance.

**Safety:** Before attaching/detaching machinery ensure the hydraulic lift system is in a neutral position.

**Safety:** Make sure the PTO drive isn't connected at any point until instructed to do so.

### You will need:

Your tractor, tractor top link arm (adjustable), linkage pins, PTO shaft, safety wear & some elbow grease! Always wear PPE protective gear when operating the chipper, including but not limited to:

- A hard hat
- Protective shoes with re-enforced toe caps and slip resistant soles
- Protective glasses, goggles or face shield
- Heavy duty gloves
- Ear protection for exposure to excessive noise levels

### Attaching The Chipper

Start by finding a flat piece of ground. Lower the three point linkage on your tractor to its lowest position and attach the machine to the tractor using the three point linkage pins and linch pins.

Adjust the length of the top link arm so that the sides of the chipper are parallel with the ground.

Check your PTO shaft's grease points and apply grease if needed. Then attach the PTO drive shaft and ensure the locking pin is secure on both the tractor and machine sides. Attach the chain to a secure point on the tractor/implement.

Start the tractor and raise the chipper so that the PTO shaft is within 15 degrees of the horizontal position. Operate the chipper with the PTO delivering 540 RPM.

### Pre-Use Checklist

Before starting the machine, always check and adjust the following:

- Adjustment of the blades. [Section 4].
- Operating procedure and advice [Section 5].
- Lubrication/grease points. [Section 6]
- Tightness of all bolts, nuts and screws.
- All protective guards are in place.

### 3. FLYWHEEL BLADE REPLACEMENT

**Safety:** Ensure tractor and machine is stopped & keys out of ignition before set-up/maintenance.

**Safety:** Always take care when handling and changing sharp blades.

There are 2 types of blade on the machine which work together to cut and chip the wood.

**A. Flywheel blades:** The flywheel is fitted with 4 blades, placed at 90°. If one is changed, the one opposite should also be replaced to remain balanced.

**B. Bed blade:** There is 1 stationary blade which acts as a stop against the moving blades.

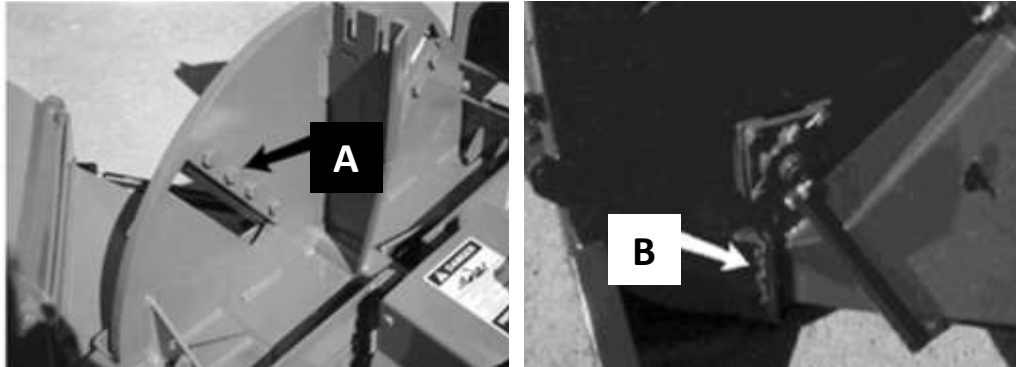

#### Signs Of Worn Blades

The best way to tell if the blades need sharpening is to look at the chippings. If they are long and stringy the blades are likely to need replacing/reversing. Also look out for a seeming lack of power, blocking of the discharge chute, and rough cutting with excessive vibration.

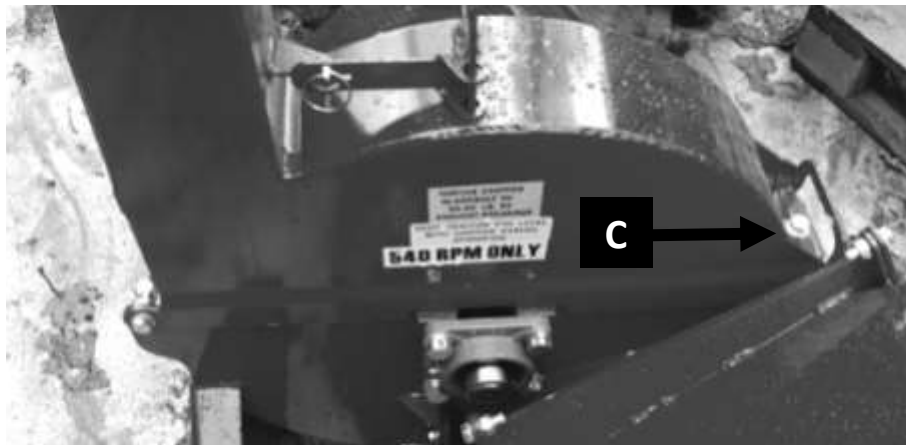

#### Changing Flywheel Blades

1. Unscrew bolt **C** and remove.
2. Pivot open the flywheel cover.
3. Unbolt the flywheel blade/blades.
4. Reverse to use the new cutting edge or replace with a new blade/blades.
5. Re-tighten blade bolts.
6. Replace the flywheel cover.
7. Re-insert bolt **C** and tighten.

## 4. BED BLADE AJUSTMENT & REPLACEMENT

**Safety:** Ensure tractor and machine is stopped & keys out of ignition before set-up/maintenance.

**Safety:** Always take care when handling and changing sharp blades.

Blades will get worn down over time and use which leads to reduced efficiency. The blades should be adjusted to ensure the wood chipper is functioning effectively.

Always ensure the bed blade is not touching the flywheel blades when the flywheel rotates. The bed blade should be adjusted to approx. 1mm clearance from the flywheel blades for best performance.

The bed blade should be adjusted regularly as the blades get worn down and always when blades are replaced.

### Bed Blade Adjustment

1. Loosen bolts **D**.
2. Use the bed blade mounting bolts to set the clearance as required. Move the bed blade within the slots to ensure the blades are not touching.
3. Check the PTO shaft is not connected and open the flywheel cover. Spin the flywheel by hand to check the clearance, the ideal clearance is approx. 1mm.
4. Tighten bolts **D**.

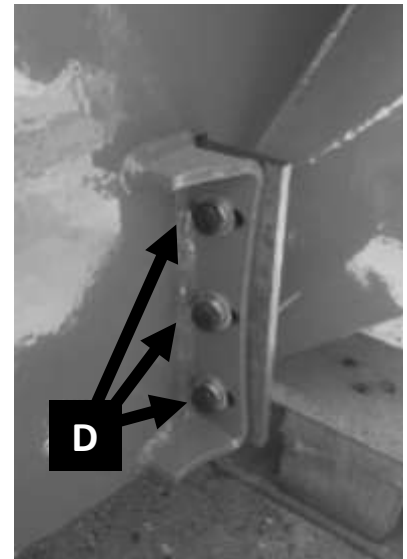

### Changing The Bed Blade

1. Loosen and remove bolts **D**.
2. Slide the blade out of the slot and replace or reverse.
3. Adjust the clearance between the bed and flywheel blades (as per instructions above).
4. Re-insert bolts **D** and tighten.



## **5. OPERATING PROCEDURE & ADVICE**

**Safety:** Ensure tractor and machine is stopped & keys out of ignition before set-up/maintenance.

**Safety:** Always take care when handling and working near sharp blades.

### **Operating Tips**

The material/branches will feed into the chipper more easily if pieces are fed in with the larger end first and the smaller parts trailing. If you have larger pieces to put through some of the branches may need to be cut off to feed through properly.

If the material stops feeding through and loses momentum, sometimes a little push from the next length of wood or branch will help.

If chips stop flowing then immediately stop feeding material into the machine. Most of the time this will be enough to clear the chips out of the unit.

If the unit slows down noticeably, turn off the PTO power and then the tractor and following the unblocking procedure.

### **Safety Tips**

Do not move the chipper or tractor while the machine is in operation.

Always set the brake on the tractor while running the chipper. You can also block the tractor wheels as an extra precaution.

Do not place metal, bottles, cans, rocks, glass or other solid material into the wood chipper. Dirt, rocks, nails, or other foreign material will also shorten the blade life and damage the machine.

### **Blockages**

Although the machine is designed to handle a wide variety of material, occasionally it may block. Stop the tractor engine, remove the ignition key and wait for all moving parts to stop before attempting to unblock the machine.

Check there is no material in the input feed and nothing is jammed or wedged between the opening and the flywheel. Loosen the input hopper nuts and raise the input hopper, this can be secured in position with the bracket at the base of the output chute. This gives access to the blades and to remove any jammed material.

Check for material in the output/discharge chute. Remove any material jammed in the discharge area.

Remove the chips from the top of the output head, remove the pivoting chip deflector for best access. Use the handle to turn the output head by hand to be sure it turns freely. Be sure to replace the chip deflector to the correct position.

Open the flywheel cover and clean out the housing. Be sure to turn the flywheel by hand to check there is nothing jammed between the flywheel blades and stationary bed blade.

## **6. SERVICING & MAINTENANCE**

**Safety:** Store all lubricants away from excessive heat, dust, moisture and contaminants.

**Safety:** Ensure tractor and machine is stopped & keys out of ignition before set-up/maintenance.

Grease Type	Multi-purpose lithium based grease
Grease Frequency	Check every 4-8 hours (top up if required)

### **Greasing & Lubrication Points**

1. Bearing on the flywheel x2 (exposed side & side behind PTO guard)
2. PTO shaft x2

Wipe grease nipples with a clean cloth before greasing to avoid injecting any dirt and grit. Press grease into each grease nipple three to five times. We recommend using a hand-held grease gun for best results.

If grease nipples will not take grease, remove and clean thoroughly. Also clean lubricant passageway. If you notice any grease points are broken replace or repair them immediately.

### **Other Maintenance**

**Blades:** Check condition of the blades and replace if worn/broken. Always take care when handling blades, wear gloves and use suitable tools for changing blades. Always check blade bolts are secured and blades are adjusted correctly.

**PTO Shaft:** Check the condition of your PTO shaft and replace if worn or damaged immediately.

**Cleaning:** Ensure the chipper is cleaned of debris, dust and chips. Remove debris is from any moving parts to prevent entanglement. After use, with the PTO shaft detached, turn the chipper by hand to make sure there no obstructions.

**Bearings:** Check the bearings. If the oil seals are damaged debris may enter the bearings. Clean and replace with new bearings if necessary. Run the chipper without a load for 3-5 minutes to check bearings are operating smoothly.

**Paintwork:** Re-coat any damaged paintwork to prevent corrosion.

**Storage:** Store the machine in a dry, level area.

**Safety Guards:** Prior to each use check the condition of the curtain/guard on the inwards feed. Replace if damaged or worn to prevent chips flying back out of the chute.

\*The periods recommended are based on normal operating conditions. Severe or unusual conditions may require more frequent maintenance.

## 7. SAFETY SIGNS

**Safety:** Ensure tractor and machine is stopped & keys out of ignition before set-up/maintenance.

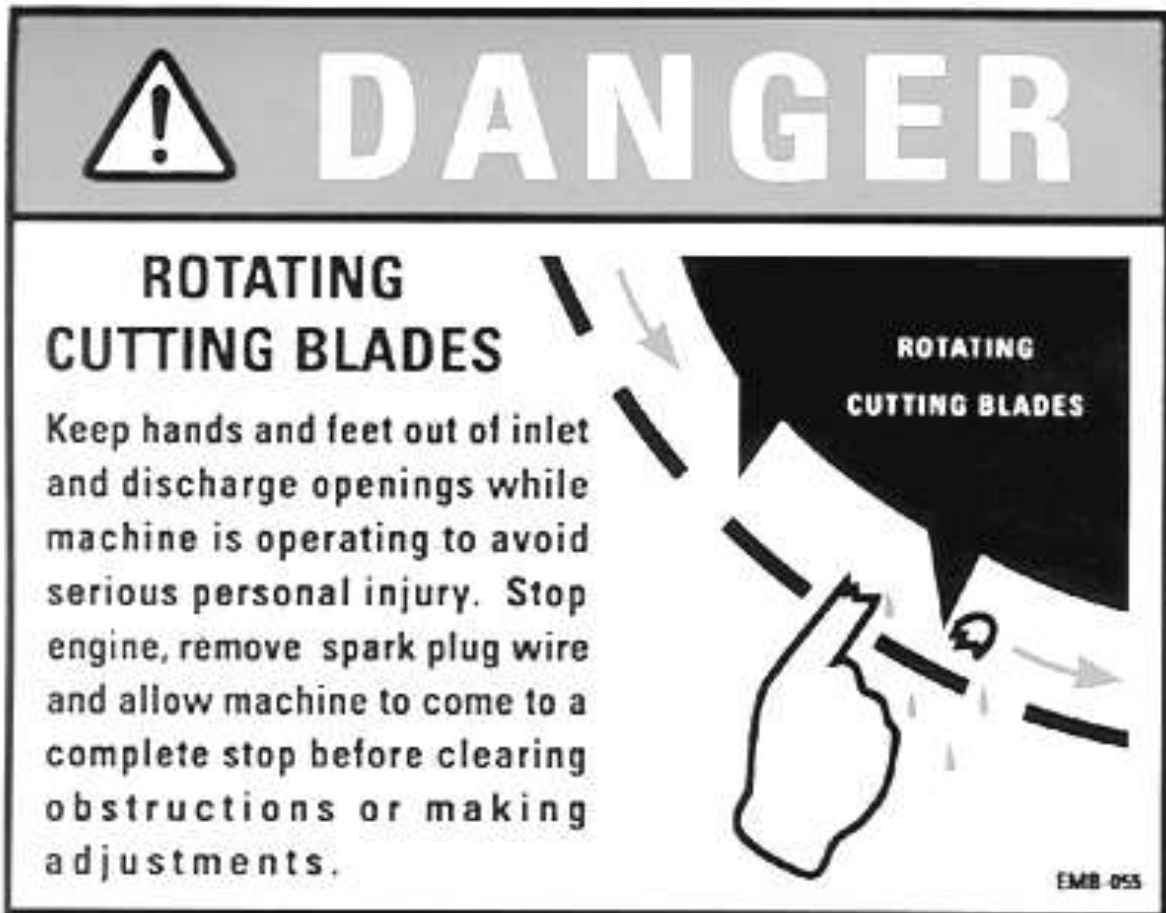

# 8. PARTS DIAGRAM 1

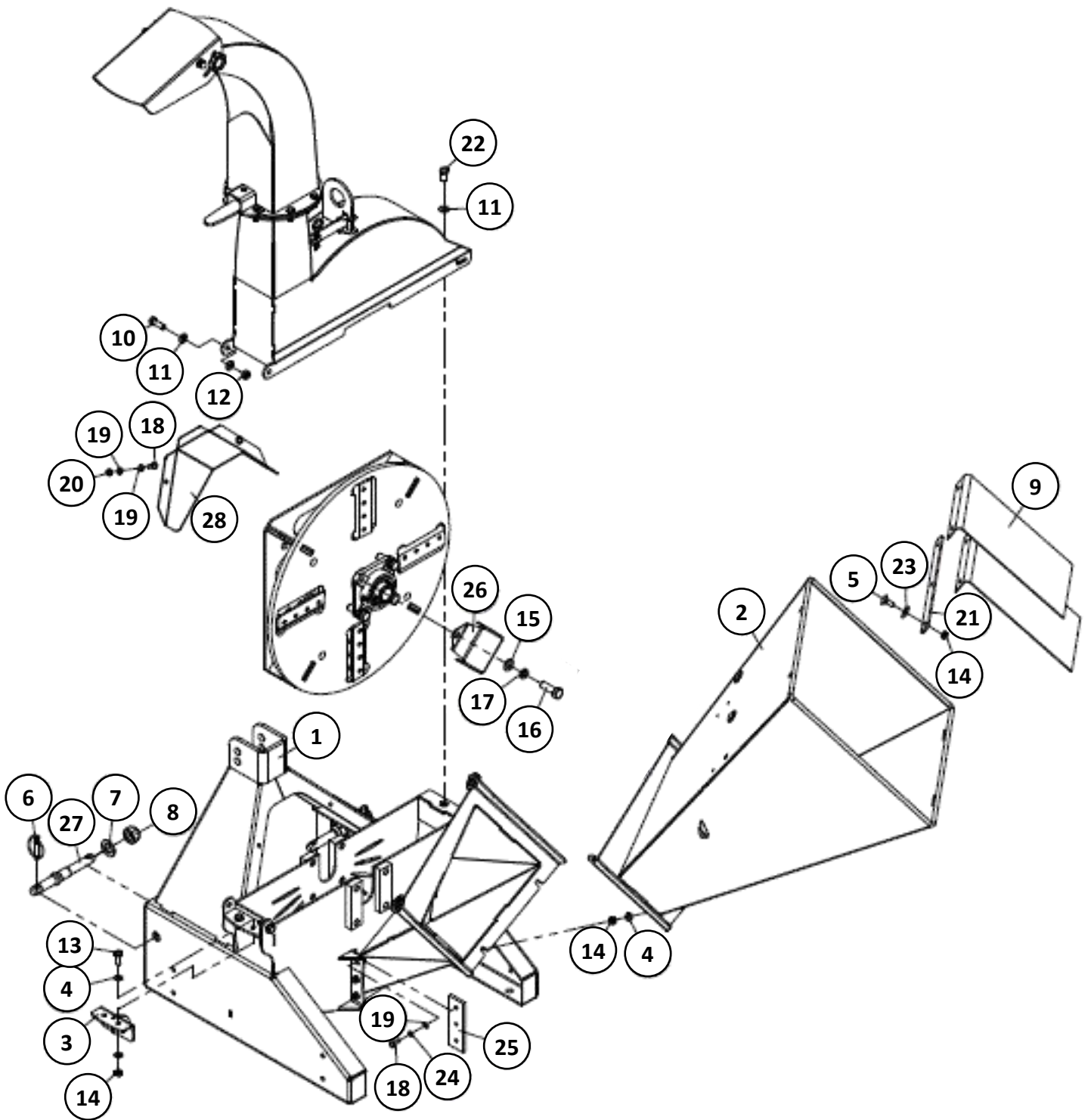

## **9. PARTS LIST 1**

<b>Dia. No.</b>	<b>Number</b>	<b>Part Number</b>	<b>Part Description</b>	<b>Qty</b>
1	804090007	WCX5-0012	Base weldment A-frame	1
2	804090001	WCX5-0011	Feeding bucket weldment	1
3	804090026	WCX5-0013	Cutting knife weldment	1
4	506010056	GB97.1-10	Plain washer	6
5	501040502	GB12-M10X25	Bolt	3
6	700080010	200.56.011	Linch pin	2
7	506010063	GB97.1-24	Plain washer	2
8	503010769	DIN985-M24	Lock nut	2
9	704090052	WCX5-0107	Rubber plate guard	2
10	501011127	GB5783-M12X35	Bolt	4
11	506010057	GB97.1-12	Plain washer	9
12	503010763	DIN985-M12	Lock nut	4
13	501011113	GB5783-M10X30	Bolt	2
14	503010762	DIN985-M10	Locknut	7
15	506010059	GB97.1-16	Plain washer	1
16	501011160	GB5783-M16X50	Bolt	1
17	506030039	GB93-16	Plain washer	1
18	501011099	GB5783-M8X20	Bolt	5
19	506010055	GB97.1-8	Plain washer	7
20	503010761	DIN985-M8	Lock nut	2
21	704090053	WCX5-0108	Pressure strip	1
22	501011125	GB5783-M12X25	Bolt	1
23	506010036	GB96.1-10	Larger washer	3
24	506030035	GB93-8	Spring washer	3
25	704090049	WCX5-0102	Stationary bed blade knife	1
26	704090066	WCX5-0109	Shaft cover	1
27	704090119	WCX5-0110	Lower linkage pin	2
28	704090125	WCX5-0111	PTO shaft cover	1

**10. PARTS DIAGRAM 2**

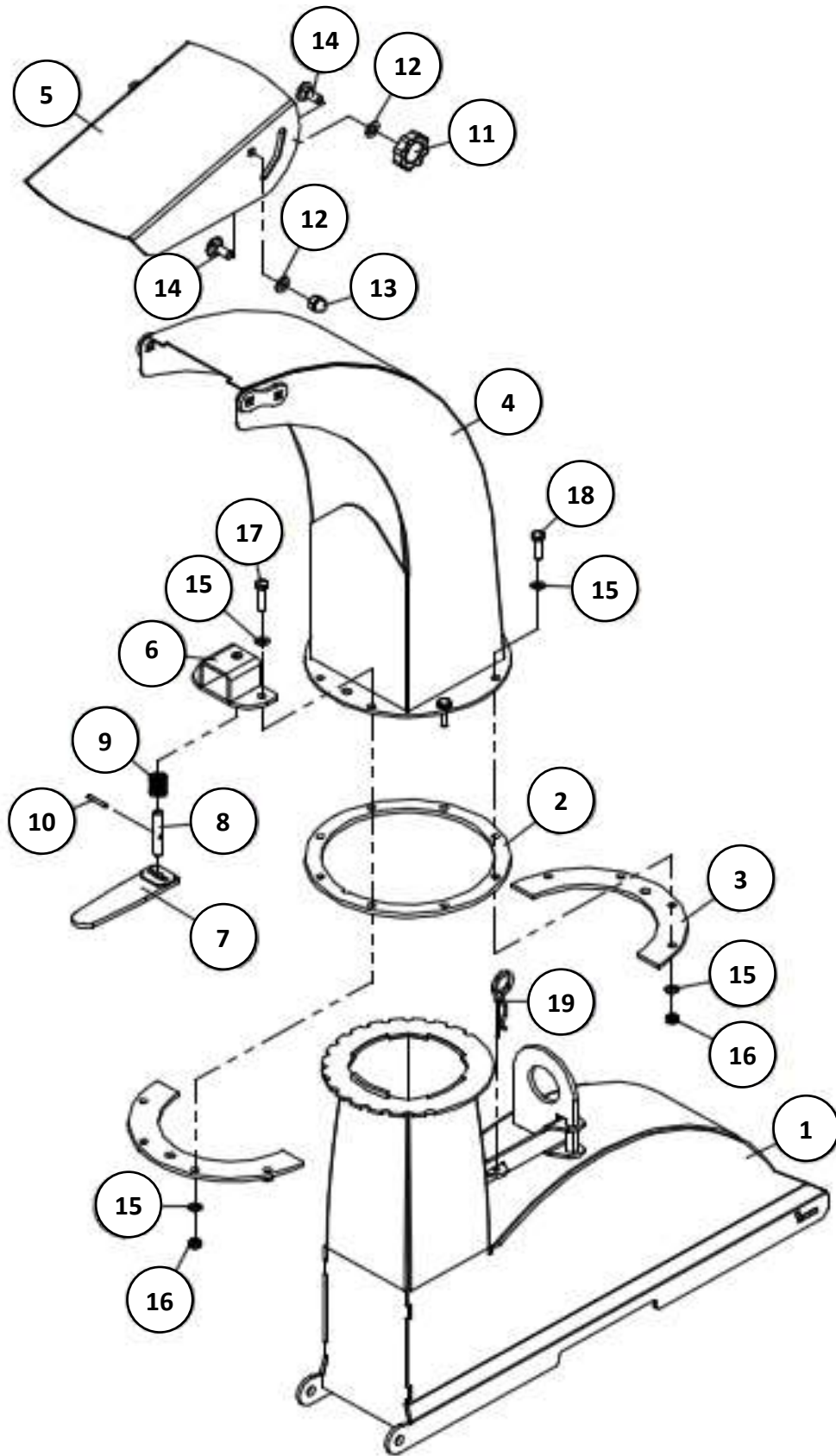

## **11. PARTS LIST 2**

<b>Dia. No.</b>	<b>Number</b>	<b>Part Number</b>	<b>Part Description</b>	<b>Qty</b>
1	804090035	WCX5-0015	Upper cover weldment	1
2	704070216	WCM8-10102	Spacer ring	1
3	704070215	WCM8-10101	Pressure plate	2
4	804090046	WCX5-0016	Discharge hood weldment	1
5	704070217	WCM8-10103	Discharge hood cover	1
6	804070152	WCM8-00041	Lock pin handle bracket	1
7	804070149	WCM8-00038A	Lock pin handle	1
8	704070218	WCM8-10104	Lock pin	1
9	702770011	AM60.01.110	Return spring	1
10	508010071	GB119.1-B-4X28	Pin	1
11	804070155	WCM8-00042	Pressure nut	2
12	506010056	GB97.1-10	Plain washer	4
13	503020125	GB923-M10	Nut	2
14	501040502	GB12-M10X25	Bolt	4
15	506010055	GB97.1-8	Plain washer	16
16	503010761	DIN985-M8	Lock nut	8
17	501011102	GB5783-M8X35	Bolt	2
18	501011101	GB5783-M8X30	Bolt	6
19	703340017	ZL-25.104	R pin	1

## 12. PARTS DIAGRAM 3

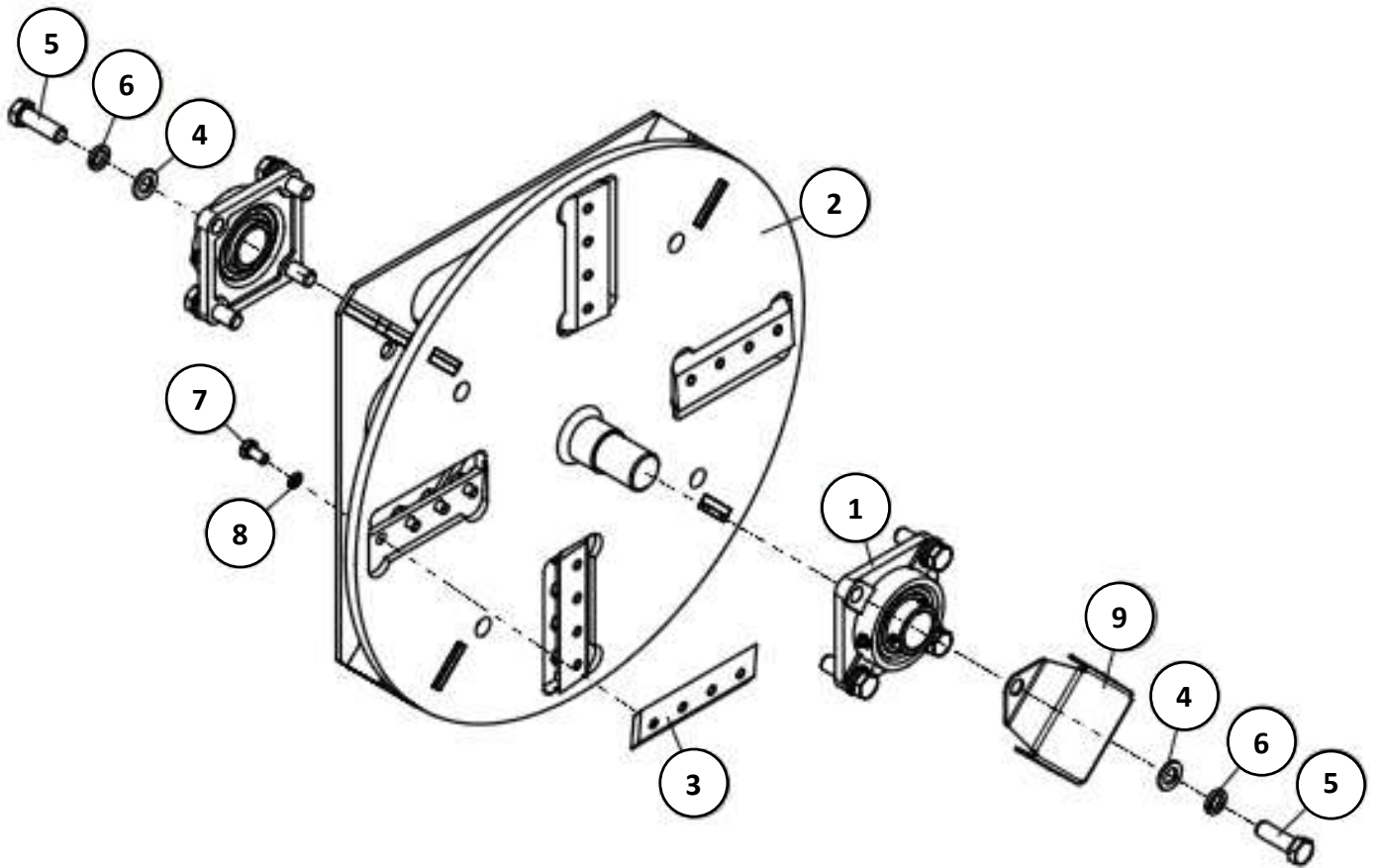

## 13. PARTS LIST 3

Dia. No.	Number	Part Number	Part Description	Qty
1	511040045	UCF208	Bearing with housing	2
2	804090029	WCX5-0014	Flywheel weldment	1
3	704090048	WCX5-0101	Flywheel blade knife	4
4	506010059	GB97.1-16	Plain washer	8
5	501011160	GB5783-M16X50	Bolt	8
6	506030039	GB93-16	Spring washer	8
7	501011111	GB5783-M10X20	Bolt	16
8	506030036	GB93-10	Spring washer	16
9	704090066	WCX5-0109	Shaft cover	1



## PTO SHAFT RESIZING

**Safety:** Ensure tractor & machine is stopped & keys out of ignition before carrying out any work. If you are not confident in carrying out the work consult your local supplier or mechanic.

Most PTO driven implements are supplied with a standard sized PTO shaft. As all tractors vary this often means cutting it down to size. Always replace worn or damaged PTO shafts.

Attach the machine to the tractor without the PTO shaft, raise the linkage so the PTO shaft is level/horizontal. Measure the length between tractor PTO and the machine's shaft. If the compressed (closed) PTO shaft length exceeds the one measured here then the driveline will need to be cut.

1. PTO length adjustment, first remove PTO shaft shielding.

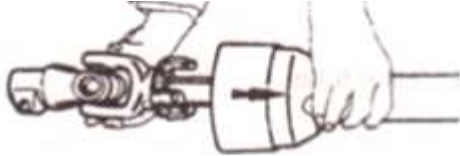

2. Shorten the driveline tubes to proper equal lengths.



3. Tidy edges of the drive tube with a file and clean all fillings from the tubes.



4. Shorten the equally long guard tubes to the same length as the driveline tubes.



5. Grease the internal driveline tube.



6. Fit the guard on the shaft.



7. Make sure that the length allows for at least 16cm (6 inches) of overlap.



## WINTON PRODUCT WARRANTY

We always strive to create great products, but when something does go wrong we have a strong network of resellers on hand throughout the UK to help out.

### Warranty Claims

Before you get in touch here are 5 pieces of information your Winton reseller will need to progress your claim:

- Your invoice/order details - to include date of purchase
- Machine model number
- Machine serial number
- Details of the fault
- Images/videos of the fault

### The Terms & Conditions

All products purchased as new are covered under our 12 month warranty from the date of purchase. During this period Winton will repair or replace defective parts free of charge. This warranty is given on the proviso that the product has been used and maintained according to the Owner's Manual.

Warranty is carried out on a return to reseller / manufacturer basis and excludes any labour or delivery / collection costs.

### Exclusions

- Wearing parts are excluded; including but not limited to blades, belts and bearings.
- Modification of the product in any way will cease the manufacturers warranty.
- The machine is warranted for one year to the original purchaser, resale within the period will cease the warranty.
- Damage in transit is not covered. Claims will need to be made through the courier or your Winton reseller directly.
- Compensation for down-time, labour or loss of earnings is not covered by the warranty.
- No warranty extension will be granted for replacement parts fitted.
- Damage caused by continued use of a faulty machine will not be covered.

Your **Winton** reseller will provide their own terms and conditions upon purchase, consult this for any additional queries.

## TROUBLE SHOOTING

**Safety:** Ensure tractor and machine is stopped & keys out of ignition before set-up/maintenance.

<b>WWC Problem</b>	<b>Solution</b>
Blockage / Jamming	Check the blades, replace if necessary Avoid material which is too 'green' Avoid chipping damp material Too low PTO speed (540rpm recommended) Remove any debris from the machine
Poor performance	Check the blades, replace if necessary Check and adjust the blade clearance Avoid material which is too 'green' Input a higher % of wood material than leaves Remove any debris from the machine Too low PTO speed (540rpm recommended)
Excessive Vibration	Check main bearings, replace if necessary Remove any debris from the machine Chop up material to a smaller size before chipping Too high PTO speed (540rpm recommended) Adjust blades so flywheel blades aren't touching the bed blade

Always consult your **Winton** dealer if you have any questions about your machine.



**W** Winton

[www.wintonmachinery.co.uk](http://www.wintonmachinery.co.uk)